

DIVISION: 06 00 00—WOOD, PLASTICS AND COMPOSITES
Section: 06 05 23—Wood, Plastic and Composite Fastenings

REPORT HOLDER:

MITEK® INC.
16023 SWINGLEY RIDGE ROAD
CHESTERFIELD, MISSOURI 63017
(800) 328-5934
www.mitek-us.com
uspcustomerservice@mii.com

EVALUATION SUBJECT:

MITEK USP SLOPABLE/SKEWABLE HANGERS FOR WOOD-FRAMED CONSTRUCTION

1.0 EVALUATION SCOPE

Compliance with the following codes:

- 2018, 2015, 2012, 2009 and 2006 *International Building Code®* (IBC)
- 2018, 2015, 2012, 2009 and 2006 *International Residential Code®* (IRC)

For evaluation for compliance with codes adopted by the Los Angeles Department of Building and Safety (LADBS), see [ESR-3446 LABC and LARC Supplement](#).

Property evaluated:

Structural

2.0 USES

The MiTek USP Slopable and Skewable Hangers used as structural connectors and described in this evaluation report (see Table 9 for a complete listing) are used to connect wood framing members in accordance with Section 2304.10.3 of the 2018 and 2015 IBC (2304.9.3 of the 2012, 2009 and 2006 IBC). The connectors may also be used in structures regulated under the IRC when an engineered design is submitted to, and approved by, the code official, in accordance with Section R301.1.3 of the 2012, 2009 and 2006 IRC.

3.0 DESCRIPTION:

3.1 LS Light Slope Hanger:

The LS Light Slope Hanger is used to connect joists to the face of the header members. The hanger has a seat that can be adjusted in the field to a maximum of 30 degrees downward from horizontal, to accommodate slopes up to

seven units vertical in twelve units horizontal. The seat depth, D, and width, W, are 3 inches (76 mm) and 1⁹/₁₆ inches (40 mm), respectively. The hanger is cold-formed from No. 18 gage steel, and is prepunched for installation with 16d common and 10d by 1¹/₂-inch-long nails. See Table 1 and Figure 1 for product dimensions, fastener schedule, allowable loads, and a typical installation detail.

3.2 LSSH Light Slopeable/Skewable Hanger:

The LSSH Light Slopeable/Skewable Hanger is designed to connect rafters to ridge beams in vaulted roof structures. The hanger can be adjusted in the field to meet a variety of skew and/or slope applications. The hanger can be adjusted for any slope angle up to 45 degrees upward or downward from horizontal, and for any skew angle up to 45 degrees left or right from perpendicular. The hanger is cold-formed from either No. 16 gage or No. 18 gage steel, and is prepunched for installation with 16d common, 10d common or 10d by 1/2-inch-long nails. See Table 2 and Figure 2 for product dimensions, fastener schedule, allowable loads, and typical installation details.

3.3 MSHL/R Strap Hanger:

The MSHL/R strap hanger is designed to allow a field-adjustable top flange, face mount or combination for supporting dimensional wood joists or open web wood trusses. The MSHL/R strap hanger is cold-formed from No. 18 gage steel, and is prepunched for installation with 10d common nails installed into the header and 10d by 1¹/₂-inch-long nails installed into the wood joists or open web wood trusses. See Table 3 and Figure 3 for product dimensions, mounting conditions, fastener schedule, allowable loads, and typical installation details.

3.4 SKH Skewed 45° Hanger:

The SKH skewed 45° hanger is designed as a face mount hanger that supports wood joists skewed either right or left at an angle of 45 degrees from perpendicular. The hanger is cold-formed from either No. 14 gage or No. 16 gage steel, and is prepunched for installation with 16d common, 10d common, or 10d by 1¹/₂-inch-long nails. See Table 4 and Figure 4 for product dimensions, fastener schedule, allowable loads, and typical installation details.

3.5 SNP Skewable Nailer Plates:

The SNP skewable nailer plate is used to connect two framing members at angles ranging from 45 to 90 degrees to one another. The nailer plate is manufactured from No. 16 gage steel, and is prepunched for installation with 8d by 1¹/₂-inch-long nails. See Table 5 and Figure 5 for product dimensions, fastener schedule, allowable loads, and typical installation details.

3.6 TMP Rafter-to-Plate Connector:

The TMP rafter-to-plate connector is designed to make rafter-to-plate connections in lieu of notching. The connector has a seat that can be field-adjusted to slopes ranging from 1:12 to 6:12 (4.76 to 26.6 degrees). The connector is cold-formed from No. 18 gage steel, and is prepunched for installation with 10d common nails into the plate and 10d by 1¹/₂-inch-long nails into the rafter. See Table 6 and Figure 6 for product dimensions, fastener schedule, allowable loads, and a typical installation detail.

3.7 TMPH Rafter-to-Plate Connector:

The TMPH rafter-to-plate connector is designed to provide a connection between a rafter and a top plate. The TMPH rafter-to-plate connector consists of a rafter seat and an adjustable fulcrum that adjusts to roof slopes ranging from 6:12 to 14:12 (26.6 to 49.4 degrees). The body of the connector is cold-formed from No. 16 gage steel, and is prepunched for installation with 10d common nails into the top plate and 10d-by-1¹/₂-inch nails into the rafter. The fulcrum component is cold-formed from No. 12 gage steel. See Table 7 and Figure 7 for product dimensions, fastener schedules, allowable loads, and a typical installation detail.

3.8 Materials:

3.8.1 Steel: The specific types of steel and corrosion protection for each product are described in Table 8 of this report. Minimum base-steel thicknesses for the different steel gages are shown in the following table:

GAGE NO.	MINIMUM BASE-STEEL THICKNESS (inch)
18	0.044
16	0.055
14	0.070
12	0.099

For SI: 1 inch = 25.4 mm.

3.8.2 Wood: Wood members must be dimensional sawn lumber, structural glued laminated timber, and metal-plate-connected wood trusses having a minimum specific gravity of 0.50, or approved engineered wood products, such as structural composite lumber (SCL) having a minimum equivalent specific gravity of 0.50, or prefabricated wood I-joists with either sawn lumber or SCL flanges, unless otherwise noted in the applicable table within this report. Wood members must have a moisture content not exceeding 19 percent (16 percent for engineered wood products), except as noted in Section 4.1. For connectors installed with nails, the thickness of the wood member must be sufficient such that the specified fasteners do not protrude through the opposite side of the member, unless otherwise permitted in the applicable table within this report. Wood members that are engineered wood products must be recognized in, and used in accordance with, a current ICC-ES evaluation report. Refer to Section 3.8.4 for issues related to the treated wood.

3.8.3 Nails: Required fastener types and sizes for use with the MiTek USP structural connectors described in this report are specified in this section and Tables 1 through 7. Nails used for connectors described in this report must be bright or hot-dipped galvanized carbon steel nails complying with material requirements, physical properties, tolerances, workmanship, protective coating and finishes, and packaging requirements specified in ASTM F1667; and must have lengths, diameters and bending yield strengths, F_{yb} , as shown in the following table:

FASTENER DESIGNATION	FASTENER LENGTH (inches)	SHANK DIAMETER (inch)	MINIMUM REQUIRED F_{yb} (psi)
8d x 1 ¹ / ₂	1.5	0.131	100,000
10d x 1 ¹ / ₂	1.5	0.148	90,000
10d common	3.0	0.148	90,000
16d common	3.5	0.162	90,000

For SI: 1 inch = 25.4 mm, 1 psi = 6,895 Pa.

Alternatively, nails of other materials or finishes may be used when they are recognized in an ICC-ES evaluation report as having bending yield strength and withdrawal capacity equal to or better than those of a bright carbon steel of the same nominal diameter.

3.8.4 Use in Treated Wood: Connectors and fasteners used in contact with preservative-treated or fire-retardant-treated wood must comply with Section 2304.10.5 of the IBC (2304.9.5 of the 2012, 2009 and 2006 IBC) or Section R317.3 of the 2012 and 2009 IRC or Section R319.3 of the 2006 IRC. The lumber treater or the report holder (MiTek Inc.), or both, should be contacted for recommendations on the appropriate level of corrosion resistance to specify for the connectors and fasteners as well as the connection capacities of the fasteners used with the specific proprietary preservative-treated or fire-retardant-treated lumber.

4.0 DESIGN AND INSTALLATION

4.1 Design:

The allowable loads in Tables 1 through 7 are based on allowable stress design. The use of the tabulated allowable loads for the products listed in Table 9 must comply with all applicable requirements and conditions specified in this evaluation report. The tabulated allowable loads are for normal load duration and/or short load duration, or both, based on load duration factors, C_D , in accordance with Section 11.3.2 of the *National Design Specification® for Wood Construction* (NDS) for the 2018 and 2015 IBC and IRC (Section 10.3.2 of the NDS for the 2012, 2009 and 2006 IBC and IRC). No further increases are permitted for load durations other than those specified. The tabulated allowable loads are for connections in wood used under continuously dry conditions where the maximum moisture content in wood is 19 percent or less (16 percent or less for engineered wood products) and sustained temperatures are limited to 100°F (37.8°C) or less. When connectors are installed in wood having a moisture content greater than 19 percent (16 percent for engineered wood products), or where the in-service moisture content in wood is expected to exceed this value, the applicable wet service factor, C_M , must be applied. Unless otherwise noted in the tables of this report, the applicable wet service factor, C_M , is as specified in Section 11.3.3 of the NDS for the 2018 and 2015 IBC and IRC (Section 10.3.3 of the NDS for the 2012, 2009 and 2006 IBC and IRC) for lateral loading of dowel-type fasteners. When connectors are installed in wood that will experience sustained exposure to temperatures exceeding 100°F (37.8°C), the allowable loads in this evaluation report must be adjusted by the temperature factor, C_t , specified in Section 11.3.4 of the NDS for 2018 and 2015 IBC and IRC (Section 10.3.4 of the NDS for the 2012, 2009 and 2006 IBC and IRC). Connected wood members must be checked for load-carrying capacity at the connection in accordance with NDS Section 11.1.2 for the 2018 and 2015 IBC and IRC (Section 10.1.2 of the NDS for the 2012, 2009 and 2006 IBC and IRC).

4.2 Installation:

Installation of the connectors must be in accordance with this evaluation report and the manufacturer’s published installation instructions. Mechanical fasteners must be installed in wood members in accordance with NDS Section 12.1.

4.3 Special Inspection:

4.3.1 Main Windforce-resisting Systems under the IBC: Periodic special inspection must be conducted for components within the main windforce-resisting system, where required in accordance with Sections 1704.2 and 1705.11 of the 2018 and 2015 IBC (1705.10 of the 2012 IBC, Sections 1704 and 1706 of the 2009 IBC, and Section 1704 of the 2006 IBC).

4.3.2 Seismic-force-resisting Systems under the IBC: Periodic special inspection must be conducted for components within the seismic-force-resisting system, where required in accordance with Sections 1704.2 and 1705.12 of the 2018 and 2015 IBC (1705.11 of the 2012 IBC, and Sections 1704 and 1707 of the 2009 and 2006 IBC).

4.3.3 Installations under the IRC: Special inspections are normally not required for connectors used in structures regulated under the IRC. However, for components and systems requiring an engineered design in accordance with IRC Section R301, periodic special inspection requirements and exemptions must be in accordance with Sections 4.3.1 and 4.3.2 of this report.

5.0 CONDITIONS OF USE

The MiTek USP connectors described in this report comply with, or are suitable alternatives to what is specified in, those codes listed in Section 1.0 of this report, subject to the following conditions:

5.1 The connectors must be manufactured, identified and installed in accordance with this report and the manufacturer’s published installation instructions. A copy of the manufacturer’s published installation instructions must be available at the jobsite at all times during installation. In the event of a conflict between this report and the manufacturer’s published installation instructions, this report governs.

5.2 Calculations showing compliance with this report must be submitted to the code official. The calculations must be prepared by a registered design professional where required by the statutes of the jurisdiction in which the project is to be constructed.

5.3 Connected wood members and fasteners must comply with Sections 3.8.2 and 3.8.3, respectively.

5.4 Adjustment factors, noted in Section 4.1 of this report and the applicable codes, must be considered in the design of the connections where applicable.

5.5 Use of connectors and fasteners with preservative-treated or fire-retardant-treated lumber must be in accordance with Section 3.8.4.

6.0 EVIDENCE SUBMITTED

Data in accordance with the ICC-ES Acceptance Criteria for Joist Hangers and Similar Devices (AC13), approved October 2018.

7.0 IDENTIFICATION

Each connector described in this report is identified by the product model (stock) number, the number of the ICC-ES index evaluation report for MiTek Inc. ([ESR-2685](#)), and by one or more of the following designations: MiTek, USP, or USP Structural Connectors.

TABLE 1—LS LIGHT SLOPE HANGER ALLOWABLE LOADS^{1, 2, 3, 4}

STORK NO.	STEEL GAGE	DIMENSIONS			FASTENER SCHEDULE				ALLOWABLE LOAD (lbs.)			
		W	H	D	Header		Joist		Download			Uplift
		(in.)			Qty.	Type	Qty.	Type	C _D = 1.0	C _D = 1.15	C _D = 1.25	C _D = 1.6
LS268	18	1 ⁹ / ₁₆	5 ¹ / ₂	3	7	10d x 1 ¹ / ₂	7	10d x 1 ¹ / ₂	840	960	1,035	675
					7	16d Common	7	10d x 1 ¹ / ₂	1,000	1,135	1,170	675
LS210	18	1 ⁹ / ₁₆	7 ⁷ / ₈	3	9	10d x 1 ¹ / ₂	9	10d x 1 ¹ / ₂	1,080	1,230	1,330	1,035
					9	16d common	9	10d x 1 ¹ / ₂	1,285	1,350	1,350	1,035

For SI: 1 inch = 25.4 mm, 1 lbf = 4.45 N.

¹Allowable loads have been adjusted for load duration factors, C_D, as shown, in accordance with the NDS. The allowable loads do not apply to loads of other durations, and are not permitted to be adjusted for other load durations. See Sections 4.1 and 4.2 for additional design and installation requirements.

²Allowable loads shown are for installations in wood members complying with Section 3.8.2.

³See Section 3.8.3 for required fastener dimensions and mechanical properties.

⁴Hangers may be field adjusted to a maximum of 30 degrees from horizontal, to accommodate slopes up to 7:12.

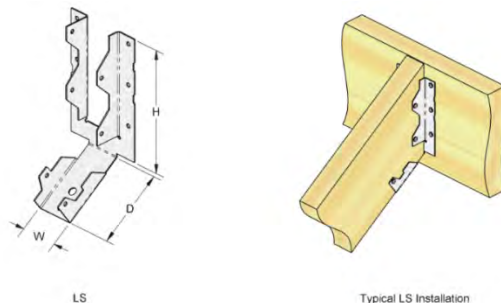

FIGURE 1—LS LIGHT SLOPE HANGER

TABLE 2—LSSH LIGHT SLOPEABLE/SKEWABLE HANGER ALLOWABLE LOADS^{1,2,3}

STOCK NO.	STEEL GAGE	DIMENSIONS (in.)					FASTENER SCHEDULE				ALLOWABLE LOADS (lbs.)			
		Joist (W)	W1	W2	H	D	Header		Joist		F _{c-perp} = 625 (psi)			Uplift
							Qty	Type	Qty	Type	C _D =1.0	C _D =1.15	C _D =1.25	C _D =1.6
Sloped only Hangers														
LSSH15-TZ	18	1½	1 ⁹ / ₁₆	1 ³ / ₄	5 ¹ / ₁₆	3	6	10d Com.	7	10d x 1½	720	820	885	565
LSSH210	18	1½	1 ⁹ / ₁₆	1 ³ / ₄	8 ¹³ / ₁₆	3	10	10d Com.	7	10d x 1½	1,200	1,370	1,395	410
LSSH179	18	1¾	1 ¹³ / ₁₆	1 ⁵ / ₈	8 ¹³ / ₁₆	3	10	10d Com.	7	10d x 1½	1,200	1,370	1,395	880
LSSH20	18	2 ¹ / ₈	2 ¹ / ₈	2½	8 ¹³ / ₁₆	3	10	10d Com.	7	10d x 1½	1,200	1,370	1,395	795
LSSH23	18	2¼-2 ⁵ / ₁₆	2 ⁵ / ₁₆	2 ³ / ₈	8 ¹³ / ₁₆	3	10	10d Com.	7	10d x 1½	1,200	1,370	1,395	945
LSSH25	16	2½	2 ⁹ / ₁₆	2¾	8 ¹³ / ₁₆	3	18	16d Com.	12	10d x 1½	2,095	2,095	2,095	945
LSSH26	16	2 ⁵ / ₈	2 ¹¹ / ₁₆	2 ⁵ / ₈	8 ¹³ / ₁₆	3	18	16d Com.	12	10d x 1½	2,095	2,095	2,095	945
LSSH31	16	3	3 ¹ / ₈	3¾	8 ¹³ / ₁₆	3	18	16d Com.	12	10d x 1½	2,645	3,000	3,115	1,310
LSSH35	16	3½	3 ⁹ / ₁₆	3½	8 ¹³ / ₁₆	3	18	16d Com.	12	10d x 1½	2,645	3,000	3,115	1,310
Skewed Hangers or Sloped and Skewed Hangers														
LSSH15-TZ	18	1½	1 ⁹ / ₁₆	1¾	5 ¹ / ₁₆	3	6	10d Com.	7	10d x 1½	620	620	620	510
LSSH210	18	1½	1 ⁹ / ₁₆	1¾	8 ¹³ / ₁₆	3	10	10d Com.	7	10d x 1½	1,200	1,370	1,395	880
LSSH179	18	1¾	1 ¹³ / ₁₆	1 ⁵ / ₈	8 ¹³ / ₁₆	3	10	10d Com.	7	10d x 1½	1,200	1,370	1,395	880
LSSH20	18	2 ¹ / ₈	2 ¹ / ₈	2½	8 ¹³ / ₁₆	3	10	10d Com.	7	10d x 1½	1,200	1,230	1,230	795
LSSH23	18	2¼-2 ⁵ / ₁₆	2 ⁵ / ₁₆	2 ³ / ₈	8 ¹³ / ₁₆	3	10	10d Com.	7	10d x 1½	1,200	1,230	1,230	795
LSSH25	16	2½	2 ⁹ / ₁₆	2¾	8 ¹³ / ₁₆	3	14	16d Com.	12	10d x 1½	1,610	1,610	1,610	945
LSSH26	16	2 ⁵ / ₈	2 ¹¹ / ₁₆	2 ⁵ / ₈	8 ¹³ / ₁₆	3	14	16d Com.	12	10d x 1½	1,610	1,610	1,610	945
LSSH31	16	3	3 ¹ / ₈	3¾	8 ¹³ / ₁₆	3	14	16d Com.	12	10d x 1½	1,610	1,610	1,610	1,310
LSSH35	16	3½	3 ⁹ / ₁₆	3½	8 ¹³ / ₁₆	3	14	16d Com.	12	10d x 1½	1,610	1,610	1,610	1,310

For SI: 1 inch = 25.4 mm, 1 lbf = 4.45 N, 1 psi = 6,895 Pa.

¹Allowable loads have been adjusted for load duration factor, C_D, as shown, in accordance with NDS. The allowable loads do not apply to loads of other load durations, and are not permitted to be adjusted for other load durations. See Section 4.1 and 4.2 for additional design and installation requirements.

²Allowable loads shown are for installation in wood members complying with Section 3.8.2. Wood members must also have a minimum reference compression perpendicular to grain design values, F_{c-perp}, as specified in the table.

³See Section 3.8.3 for required fastener dimensions and mechanical properties.

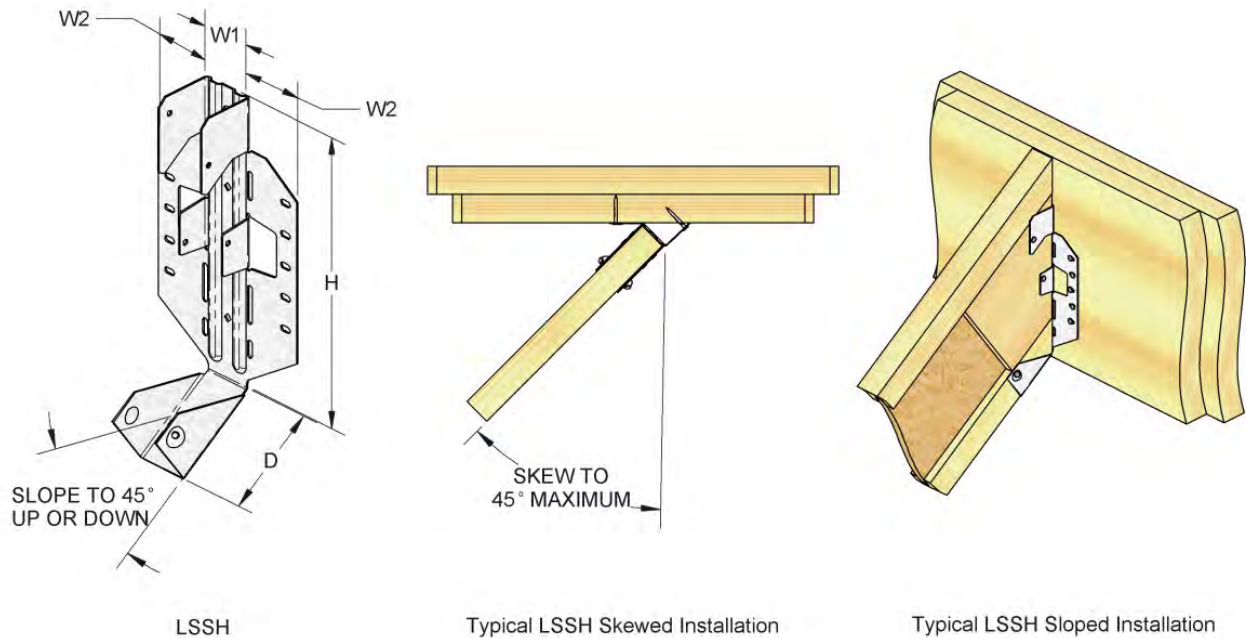

FIGURE 2—LSSH LIGHT SLOPEABLE/SKEWABLE HANGER

TABLE 3—MSH L/R STRAP HANGER ALLOWABLE LOADS^{1,2,3}

STOCK NO.	STEEL GAGE	DIMENSION (in.)				MOUNTING ⁴ CONDITION	FASTENERS					ALLOWABLE LOAD (lbs)			
							Header		Joist			Download			Uplift
		W	D	H	B		Top	Face	Type	Qty	Type	C _D = 1.0	C _D = 1.15	C _D = 1.25	C _D = 1.6
							Qty.	Qty.							
MSH213 L/R	18	1 ⁵ / ₈	2 ¹ / ₄	13 ¹ / ₄	5	Face-Max	-	22	10d Common	6	10d x 1 ¹ / ₂	1,770	1,770	1,770	670
						Top-Max	4	6	10d Common	6	10d x 1 ¹ / ₂	1,810	1,810	1,810	670
						Top-Min	4	2	10d Common	6	10d x 1 ¹ / ₂	1,325	1,325	1,325	-
MSH422 L/R	16	3 ⁹ / ₁₆	2	22	5 ¹ / ₈	Face-Max	-	14	10d Common	6	10d Common	1,750	1,755	1,755	560
						Top-Max	4	6	10d Common	6	10d Common	1,820	1,820	1,820	560
						Top-Min	4	2	10d Common	6	10d Common	1,385	1,385	1,385	-

For SI: 1 inch = 25.4 mm, 1 lbf = 4.45 N, 1 psi = 6,895 Pa.

¹Allowable loads have been adjusted for load duration factors, C_D, as shown, in accordance with the NDS. The allowable loads do not apply to loads of other durations, and are not permitted to be adjusted for other load durations. See Sections 4.1 and 4.2 for additional design and installation requirements.

²Allowable loads shown are for installations in wood members complying with Section 3.8.2. Wood members must also have a minimum reference compression perpendicular to grain design value, F_{C-perp}, of 460 psi (3.17 MPa).

³See Section 3.8.3 for required fastener dimensions and mechanical properties.

⁴See Figure 3 for installation details. Mounting conditions are as follows:

Face-Max – The specified number of header nails must be driven into the wide face of the header.

Top-Max – The hanger is installed in a top mount condition with at least six nail holes filled on the face of the header, and four nail holes filled on the top of the header. The straps must wrap over the top of the header at least 2.5 inches (63.5 mm).

Top-Min – The hanger is installed in a top mount condition with at least the top two nail holes filled on the face of the header, and four nail holes filled on the top of the header. The straps must wrap over the top of the supporting member at least 2.5 inches (63.5 mm).

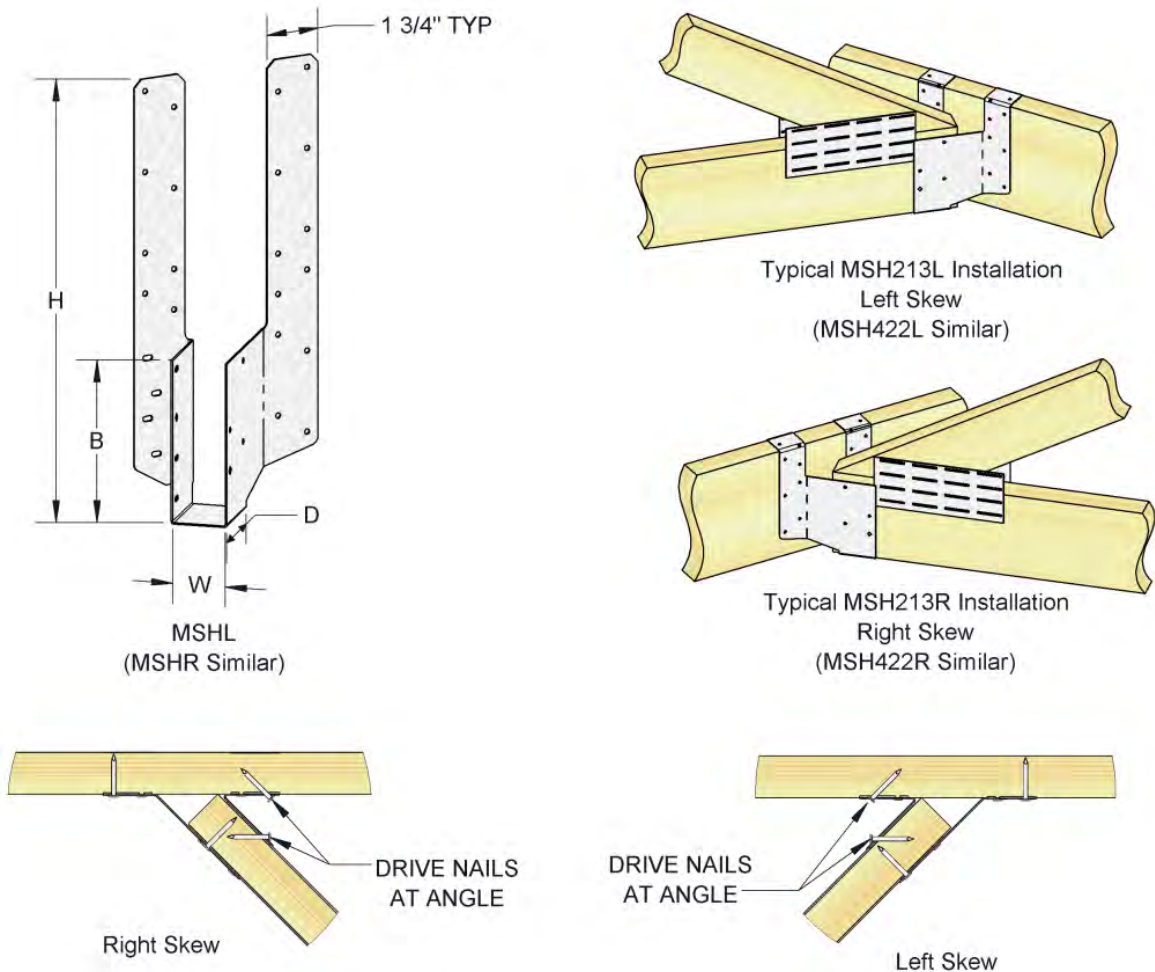

FIGURE 3—MSH L/R STRAP HANGER

TABLE 4—SKH SKEWED 45° HANGER ALLOWABLE LOADS^{1,2,3}

STOCK NO.	STEEL GAGE	DIMENSIONS (in.)			FASTENER SCHEDULE				ALLOWABLE LOADS (lbs.)						
					Header		Joist		F _{C-perp} = 460 psi			F _{C-perp} = 625 psi			Uplift
		W	H	D	Face	Type	Qty	Type	C _D = 1.0	C _D = 1.15	C _D = 1.25	C _D = 1.0	C _D = 1.15	C _D = 1.25	C _D = 1.6
SKH24L/R	16	1 ⁹ / ₁₆	3 ¹ / ₄	1 ⁷ / ₈	4	16d Common	4	10dx1 ¹ / ₂	510	510	510	510	510	510	545
SKH26L/R	16	1 ⁹ / ₁₆	5 ¹ / ₄	1 ⁷ / ₈	6	16d Common	6	10dx1 ¹ / ₂	840	890	890	840	890	890	1,135
SKH28L/R	16	1 ⁹ / ₁₆	7 ¹ / ₄	1 ⁷ / ₈	10	16d Common	8	10dx1 ¹ / ₂	1,400	1,465	1,465	1,400	1,465	1,465	1,350
SKH210L/R	16	1 ⁹ / ₁₆	9 ¹ / ₄	1 ⁷ / ₈	14	16d Common	10	10dx1 ¹ / ₂	1,790	1,790	1,790	1,790	1,790	1,790	1,530
SKH1720L/R	16	1 ¹³ / ₁₆	9 ¹ / ₈	1 ⁷ / ₈	14	10d Common	10	10dx1 ¹ / ₂	1,650	1,760	1,760	1,650	1,760	1,760	1,530
SKH1724L/R	16	1 ¹³ / ₁₆	11 ¹ / ₈	1 ⁷ / ₈	16	10d Common	10	10dx1 ¹ / ₂	1,890	2,170	2,360	1,890	2,170	2,360	1,530
SKH2020L/R	16	2 ¹ / ₈	9	1 ⁷ / ₈	14	10d Common	10	10dx1 ¹ / ₂	1,650	1,760	1,760	1,650	1,760	1,760	1,530
SKH2024L/R	16	2 ¹ / ₈	11	1 ⁷ / ₈	16	10d Common	10	10dx1 ¹ / ₂	1,890	2,170	2,360	1,890	2,170	2,360	1,530
SKH2320L/R	16	2 ³ / ₈	8 ⁷ / ₈	1 ⁷ / ₈	14	10d Common	10	10dx1 ¹ / ₂	1,650	1,760	1,760	1,650	1,760	1,760	1,530
SKH2324L/R	16	2 ³ / ₈	10 ⁷ / ₈	1 ⁷ / ₈	16	10d Common	10	10dx1 ¹ / ₂	1,890	2,170	2,360	1,890	2,170	2,360	1,530
SKH36L/R	16	2 ⁹ / ₁₆	4 ³ / ₄	1 ³ / ₈	6	16d Common	6	10dx1 ¹ / ₂	840	965	1,050	840	965	1,050	1,135
SKH38L/R	16	2 ⁹ / ₁₆	6 ³ / ₄	1 ³ / ₈	10	16d Common	8	10dx1 ¹ / ₂	1,400	1,550	1,550	1,400	1,550	1,550	1,510
SKH310L/R	16	2 ⁹ / ₁₆	8 ³ / ₄	1 ³ / ₈	14	16d Common	10	10dx1 ¹ / ₂	2,060	2,365	2,465	2,060	2,365	2,465	1,530
SKH312L/R	16	2 ⁹ / ₁₆	10 ³ / ₄	1 ³ / ₈	16	16d Common	10	10dx1 ¹ / ₂	2,350	2,705	2,750	2,350	2,705	2,750	1,530
SKH2520L/R	16	2 ⁹ / ₁₆	8 ⁵ / ₈	1 ⁷ / ₈	14	10d Common	10	10dx1 ¹ / ₂	1,650	1,760	1,760	1,650	1,760	1,760	1,530
SKH2524L/R	16	2 ⁹ / ₁₆	10 ³ / ₄	1 ⁷ / ₈	16	10d Common	10	10dx1 ¹ / ₂	1,890	2,170	2,360	1,890	2,170	2,360	1,530
SKH2620L/R	16	2 ¹¹ / ₁₆	8 ¹ / ₁₆	1 ⁷ / ₈	14	10d Common	10	10dx1 ¹ / ₂	1,650	1,760	1,760	1,650	1,760	1,760	1,530
SKH2624L/R	16	2 ¹¹ / ₁₆	10 ¹ / ₁₆	1 ⁷ / ₈	16	10d Common	10	10dx1 ¹ / ₂	1,890	2,170	2,360	1,890	2,170	2,360	1,530
* SKH26L/R-2	16	3 ¹ / ₁₆	4 ¹ / ₂	1 ³ / ₈	6	16d Common	6	10d Common	840	965	1,050	840	965	1,050	1,135
* SKH28L/R-2	16	3 ¹ / ₁₆	6 ¹ / ₂	1 ³ / ₈	10	16d Common	8	10d Common	1,400	1,610	1,750	1,400	1,610	1,750	1,350
* SKH210L/R-2	16	3 ¹ / ₁₆	8 ¹ / ₂	1 ³ / ₈	14	16d Common	10	10d Common	1,960	2,255	2,450	1,960	2,255	2,450	1,530
* SKH212-2L/R	16	3 ¹ / ₁₆	10 ¹ / ₂	1 ³ / ₈	16	16d Common	10	10d Common	2,240	2,575	2,800	2,240	2,575	2,800	1,530
* SKH46L/R	14	3 ⁹ / ₁₆	4 ³ / ₄	2 ¹ / ₂	10	16d Common	6	16d Common	1,440	1,590	1,590	1,440	1,590	1,590	1,350
* SKH410L/R	14	3 ⁹ / ₁₆	8 ¹ / ₂	2 ¹ / ₂	16	16d Common	10	16d Common	2,305	2,650	2,865	2,305	2,650	2,865	1,530
* SKH414L/R	14	3 ⁹ / ₁₆	12 ¹ / ₂	2 ¹ / ₂	22	16d Common	10	16d Common	3,170	3,645	3,960	3,170	3,645	3,960	1,530
* SKH2020L/R-2	14	4 ³ / ₁₆	9 ¹ / ₄	3 ¹ / ₂	14	10d Common	10	10d Common	1,710	1,965	2,135	1,710	1,965	2,135	1,645
* SKH2024L/R-2	14	4 ³ / ₁₆	11 ¹ / ₄	3 ¹ / ₂	16	10d Common	10	10d Common	1,950	2,245	2,440	1,950	2,245	2,440	1,680
* SKH2320L/R-2	14	4 ⁷ / ₈	9 ¹ / ₄	3 ¹ / ₂	14	10d Common	10	10d Common	1,710	1,965	2,135	1,710	1,965	2,135	1,645
* SKH2324L/R-2	14	4 ⁷ / ₈	11 ¹ / ₄	3 ¹ / ₂	16	10d Common	10	10d Common	1,950	2,245	2,440	1,950	2,245	2,440	1,680
* SKH2520L/R-2	14	5 ¹ / ₈	9 ¹ / ₄	3 ¹ / ₂	14	10d Common	10	10d Common	1,710	1,965	2,135	1,710	1,965	2,135	1,645
* SKH2524L/R-2	14	5 ¹ / ₈	11 ¹ / ₄	3 ¹ / ₂	16	10d Common	10	10d Common	1,950	2,245	2,440	1,950	2,245	2,440	1,680

For **SI**: 1 inch = 25.4 mm, 1 lbf = 4.45 N, 1 psi = 6,895 Pa.

¹Allowable loads have been adjusted for load duration factors, C_D, as shown, in accordance with the NDS. The allowable loads do not apply to loads of other durations, and are not permitted to be adjusted for other load durations. See Section 4.1 and 4.2 for additional design and installation requirements.

²See Section 3.8.3 for required fastener dimensions and mechanical properties.

³Allowable loads shown are for installations in wood members complying with Section 3.8.2. Wood members must also have a minimum reference compression perpendicular to grain design value, F_{C-perp}, of either 460 psi (3.17 MPa), or 625 psi (4.31 MPa), as specified in the table above.

* Denotes models for which joist ends must either be miter-cut at a 45-degree angle to provide maximum bearing area in the hanger seat. In multi-ply I-joist applications, miter cuts are not required, provided the I-joists are staggered in the hanger such that the nearest corner of each I-joist is within 1/8-inch (3.18 mm) of the face of the supporting member.

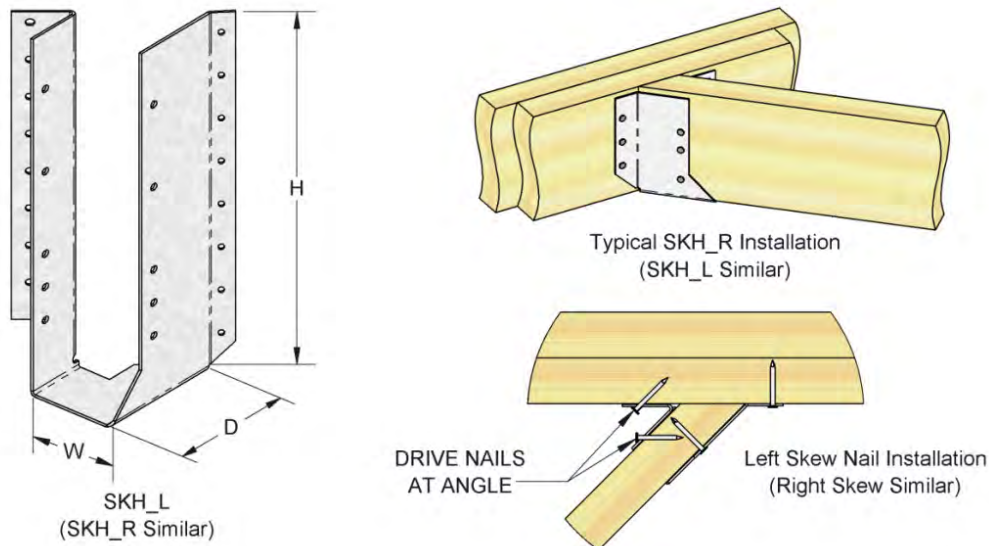

FIGURE 4—SKH SKEWED 45° HANGER

TABLE 5—NAILING SCHEDULES, DIMENSIONS AND ALLOWABLE LOADS FOR SNP SKEWABLE NAILER PLATE

STOCK NUMBER	STEEL GAGE	HANGER DIMENSIONS (inches)			FASTENER SCHEDULE ³				ALLOWABLE LOADS (lbs.) ^{1,2,5}			
					Supporting Member		Supported Member		Download			Uplift
		W1	W2	H	Qty ⁴	Type ³	Qty ⁴	Type ³	C _D = 1.00	C _D = 1.15	C _D = 1.25	C _D = 1.60
SNP3	16	3 1/2	3 1/2	3 3/8	6	8d x 1 1/2	6	8d x 1 1/2	475	475	475	475

For S1: 1 inch = 25.4 mm, 1 lbf = 4.45 N.

¹Allowable loads have been adjusted for load duration factors, C_D, as shown, in accordance with the NDS, and are not permitted to be adjusted for other load durations. See Section 4.1 for additional design requirements.

²Allowable loads shown are for installations in sawn lumber or structural composite lumber complying with Section 3.8.2.

³See Section 3.8.3 for required nail dimensions and mechanical properties.

⁴Install specified fasteners into the wide faces of the members, from the bend line out on each flange of SNP nailer plate. Not all nail holes will be filled.

⁵The SNP was tested for use with a bend angle of 90 to 135 degrees between SNP flanges, corresponding to a joist skew from 0 to 45 degrees from perpendicular to the supporting truss member. Refer to Top View of Figure 5 for details.

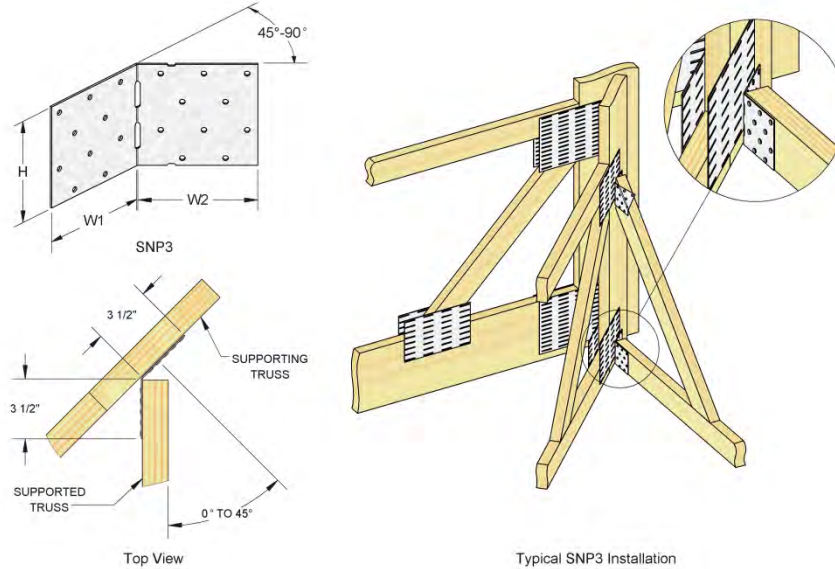

FIGURE 5—DIMENSIONS AND INSTALLATION OF SNP SKEWABLE NAILER PLATE

TABLE 6—TMP ADJUSTABLE RAFTER-TO-PLATE CONNECTOR ALLOWABLE LOADS^{1, 2, 3}

STOCK NO.	STEEL GAGE	DIMENSIONS (in.)				FASTENER SCHEDULE				ALLOWABLE LOADS (lbs.)							
		Joist (W)	W	L	D	Plate		Rafter		F _{C-perp} = 460 psi			F _{C-perp} = 625 psi			Uplift ³	
						Qty	Type	Qty	Type	C _D = 1.0	C _D = 1.15	C _D = 1.25	C _D = 1.0	C _D = 1.15	C _D = 1.25		
TMP2	18	1 1/2	1 9/16	5 9/16	3 1/2	6	10d Common	4	10dx1 1/2	1,705	1,705	1,705	1,705	1,705	1,705	1,705	245
TMP175	18	1 3/4	1 13/16	5 9/16	3 1/2	6	10d Common	4	10dx1 1/2	1,705	1,705	1,705	1,705	1,705	1,705	1,705	245
TMP21	18	2 - 2 1/8	2 1/8	6 3/8	3 1/2	6	10d Common	4	10dx1 1/2	1,705	1,705	1,705	1,705	1,705	1,705	1,705	245
TMP23	18	2 5/16	2 3/8	6 3/8	3 1/2	6	10d Common	4	10dx1 1/2	1,705	1,705	1,705	1,705	1,705	1,705	1,705	245
TMP25	18	2 1/2 - 2 9/8	2 11/16	6 3/8	3 1/2	6	10d Common	4	10dx1 1/2	1,705	1,705	1,705	1,705	1,705	1,705	1,705	245
TMP31	18	3	3 1/8	7 5/16	3 1/2	6	10d Common	4	10dx1 1/2	1,705	1,705	1,705	1,705	1,705	1,705	1,705	245
TMP4	18	3 1/2	3 9/16	7 5/16	3 1/2	6	10d Common	4	10dx1 1/2	1,705	1,705	1,705	1,705	1,705	1,705	1,705	245

For S1: 1 inch = 25.4 mm, 1 lbf = 4.45 N, 1 psi = 6,895 Pa.

¹Allowable loads have been adjusted for load duration factors, C_D, as shown, in accordance with the NDS. The allowable loads do not apply to loads of other durations, and are not permitted to be adjusted for other load durations. See Sections 4.1 and 4.2 for additional design and installations requirements.

²See Section 3.8.3 for required fastener dimensions and mechanical properties.

³Allowable loads shown are for installations in wood members complying with Section 3.8.2. Wood members must also have a minimum reference compression perpendicular to grain design value, F_{C-perp}, of either 460 psi (3.17 MPa), or 625 psi (4.31 MPa), as specified in the table above.

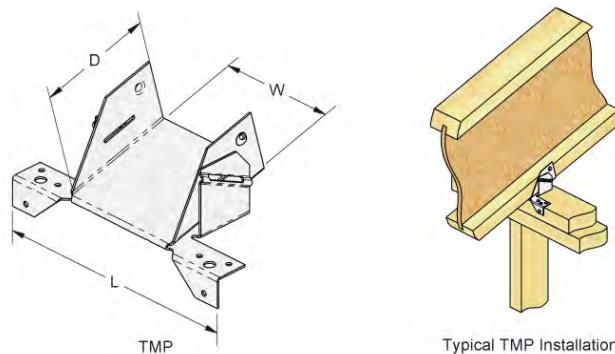

FIGURE 6—TMP RAFTER-TO-PLATE CONNECTOR

TABLE 7—TMPH RAFTER-TO-PLATE CONNECTOR ALLOWABLE LOADS^{1,2,3,4}

STOCK NO.	STEEL GAGE	DIMENSIONS (in.)				FASTENER SCHEDULE					
		W	L	D	H	Plate				Rafter	
						Top		Side			
						Qty	Type	Qty	Type	Qty	Type
TMPH2	16	1 ⁹ / ₁₆	6 ⁹ / ₁₆	4	2 ¹ / ₂	8	10d Common	2	10d Common	8	10d x 1 ¹ / ₂
TMPH175	16	1 ¹³ / ₁₆	6 ⁹ / ₁₆	4	2 ³ / ₈	8	10d Common	2	10d Common	8	10d x 1 ¹ / ₂
TMPH21	16	2 ¹ / ₈	7 ³ / ₈	4	2 ⁵ / ₈	8	10d Common	2	10d Common	8	10d x 1 ¹ / ₂
TMPH23	16	2 ³ / ₈	7 ³ / ₈	4	2 ¹ / ₂	8	10d Common	2	10d Common	8	10d x 1 ¹ / ₂
TMPH25	16	2 ¹¹ / ₁₆	7 ³ / ₈	4	2 ⁵ / ₁₆	8	10d Common	2	10d Common	8	10d x 1 ¹ / ₂
TMPH 31	16	3 ¹ / ₈	8 ⁹ / ₁₆	4	2 ¹¹ / ₁₆	8	10d Common	2	10d Common	8	10d x 1 ¹ / ₂
TMPH4	16	3 ⁹ / ₁₆	8 ⁹ / ₁₆	4	2 ¹ / ₂	8	10d Common	2	10d Common	8	10d x 1 ¹ / ₂

STOCK NO.	ALLOWABLE LOADS (lbs.)									
	Downward Load (C _D = 1.15)									Uplift (C _D = 1.6)
	Rafter Pitch									
	6/12	7/12	8/12	9/12	10/12	11/12	12/12	13/12	14/12	6/12 – 14/12
TMPH2	3,190	3,290	3,390	3,140	2,900	2,710	2,520	2,230	1,950	330
TMPH175	3,190	3,290	3,390	3,140	2,900	2,710	2,520	2,230	1,950	330
TMPH21	3,190	3,290	3,390	3,140	2,900	2,710	2,520	2,230	1,950	330
TMPH23	3,190	3,290	3,390	3,140	2,900	2,710	2,520	2,230	1,950	330
TMPH25	3,190	3,290	3,390	3,140	2,900	2,710	2,520	2,230	1,950	330
TMPH 31	3,190	3,290	3,390	3,140	2,900	2,710	2,520	2,230	1,950	330
TMPH4	3,190	3,290	3,390	3,140	2,900	2,710	2,520	2,230	1,950	330

For SI: 1 inch = 25.4 mm, 1 lbf = 4.45 N, 1 psi = 6,895 Pa.

¹Allowable loads have been adjusted for load duration factors, C_D, as shown, in accordance with the NDS. The allowable loads do not apply to loads of other durations, and are not permitted to be adjusted for other load durations. See Sections 4.1 and 4.2 for additional design and installation requirements.

²Allowable loads shown are for installations in wood members complying with Section 3.8.2. Wood members must also have a minimum reference compression perpendicular to grain design value, F_{C-perp}, of 460 psi (3.17 MPa).

³See Section 3.8.3 for required fastener dimensions and mechanical properties.

⁴The TMPH rafter-to-plate connector may not be used to resist lateral loads parallel or perpendicular to the top plate.

⁵The fulcrum component is cold-formed from No. 12 gage steel.

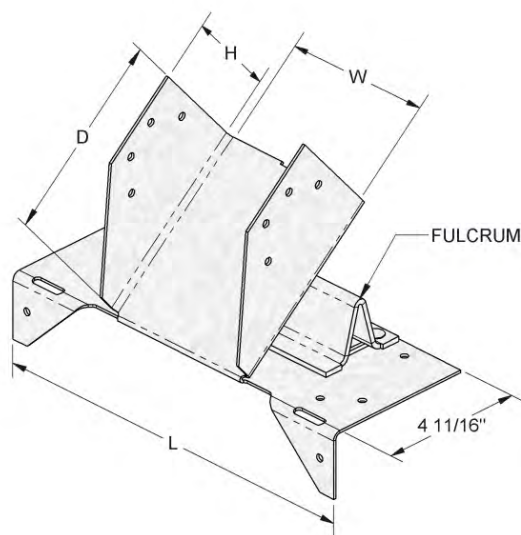

TMPH

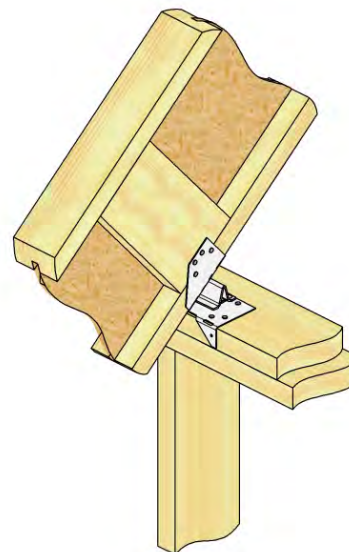

Typical TMPH Installation

FIGURE 7—TMPH RAFTER-TO-PLATE CONNECTOR

TABLE 8—STEEL TYPE, STRENGTH AND CORROSION RESISTANCE

PRODUCT	STEEL	COATING
LS Light Slope Hanger	ASTM A653, SS designation, Grade 40	G90 ¹
LSSH Light Slopeable/Skewable Hanger	ASTM A653, SS designation, Grade 40	G90 ¹ , G185 ¹
MSH213L/R Strap Hanger	ASTM A653, SS designation, Grade 40	G90 ¹ , G185 ¹
SKH Skewed 45° Hanger	ASTM A653, SS designation, Grade 40	G90 ¹ , G185 ¹
SNP Skewable Nailer Plate	ASTM A653, SS designation, Grade 40	G90 ¹
TMP Rafter-to-Plate Connector	ASTM A653, SS designation, Grade 40	G90 ¹
TMPH Rafter-to-Plate Connector	ASTM A653, SS designation, Grade 40	G90 ¹

¹Corrosion protection is a zinc coating of sheet steel in accordance with ASTM A653.

TABLE 9—CROSS-REFERENCE OF PRODUCT NAMES WITH APPLICABLE REPORT SECTIONS, TABLES AND FIGURES

PRODUCT NAME	REPORT SECTION	TABLE NO.	FIGURE NO.
LS Light Slope Hanger	3.1	1	1
LSSH Light Slopeable/Skewable Hanger	3.2	2	2
MSH213L/R Strap Hanger	3.3	3	3
SKH Skewed 45° Hanger	3.4	4	4
SNP Skewable Nailer Plate	3.5	5	5
TMP Rafter-to-Plate Connector	3.6	6	6
TMPH Rafter-to-Plate Connector	3.7	7	7

DIVISION: 06 00 00—WOOD, PLASTICS AND COMPOSITES
Section: 06 05 23—Wood, Plastics, and Composite Fastenings

REPORT HOLDER:

MITEK INC.

EVALUATION SUBJECT:

MITEK USP SLOPABLE/SKEWABLE HANGERS FOR WOOD-FRAMED CONSTRUCTION

1.0 REPORT PURPOSE AND SCOPE

Purpose:

The purpose of this evaluation report supplement is to indicate that MiTek USP slopable/skewable hangers for wood-framed construction, described in ICC-ES evaluation report [ESR-3446](#), have also been evaluated for compliance with the codes noted below as adopted by the Los Angeles Department of Building and Safety (LADBS).

Applicable code editions:

- 2020 *City of Los Angeles Building Code* (LABC)
- 2020 *City of Los Angeles Residential Code* (LARC)

2.0 CONCLUSIONS

The MiTek USP slopable/skewable hangers for wood-framed construction, described in Sections 2.0 through 7.0 of the evaluation report [ESR-3446](#), comply with the LABC Chapter 23, and the LARC, and are subjected to the conditions of use described in this supplement.

3.0 CONDITIONS OF USE

The MiTek USP slopable/skewable hangers for wood-framed construction, described in this evaluation report must comply with all of the following conditions:

- All applicable sections in the evaluation report [ESR-3446](#).
- The design, installation, conditions of use and labeling are in accordance with the 2018 *International Building Code*® (2018 IBC) provisions noted in the evaluation report [ESR-3446](#).
- The design, installation and inspection are in accordance with additional requirements of LABC Chapters 16 and 17, as applicable.
- Under the LARC, an engineered design in accordance with LARC Section R301.1.3 must be submitted.

This supplement expires concurrently with the evaluation report, reissued October 2020.

DIVISION: 06 00 00—WOOD, PLASTICS AND COMPOSITES
Section: 06 05 23—Wood, Plastic, and Composite Fastenings

REPORT HOLDER:

MITEK INC.

EVALUATION SUBJECT:

MITEK USP SLOPABLE/SKEWABLE HANGERS FOR WOOD-FRAMED CONSTRUCTION

1.0 REPORT PURPOSE AND SCOPE

Purpose:

The purpose of this evaluation report supplement is to indicate that MiTek USP Slopable and Skewable Hangers for wood-framed construction, described in ICC-ES evaluation report ESR-3446, have also been evaluated for compliance with the codes noted below.

Applicable code editions:

- 2020 and 2017 *Florida Building Code—Building*
- 2020 and 2017 *Florida Building Code—Residential*

2.0 CONCLUSIONS

The MiTek USP Slopable and Skewable Hangers for wood-framed construction, described in Sections 2.0 through 7.0 of the evaluation report ESR-3446, comply with the *Florida Building Code—Building* and the *Florida Building Code—Residential*, provided the design requirements are determined in accordance with the *Florida Building Code—Building* or the *Florida Building Code—Residential*, as applicable. The installation requirements noted in ICC-ES evaluation report ESR-3446 for the 2018 and 2015 *International Building Code*® meet the requirements of the *Florida Building Code—Building* or the *Florida Building Code—Residential*, as applicable.

Use of the MiTek USP Slopable and Skewable Hangers for wood-framed construction has also been found to be in compliance with the High-Velocity Hurricane Zone (HVHZ) provisions of the *Florida Building Code—Building*, and the *Florida Building Code—Residential* with following condition:

- a) For connections subject to uplift, the connection must be designed for no less than 700 pounds (3114 N).

For products falling under Florida Rule 61G20-3, verification that the report holder's quality assurance program is audited by a quality assurance entity approved by the Florida Building Commission for the type of inspections being conducted is the responsibility of an approved validation entity (or the code official, when the report holder does not possess an approval by the Commission).

This supplement expires concurrently with the evaluation report ESR-3446, reissued October 2020.